

AUTOMOTIVE ALTERNATOR CONVERSION FOR N750G

I'm in the process of upgrading my Helicycle charging system to a 55-Amp automobile alternator. Here's why:

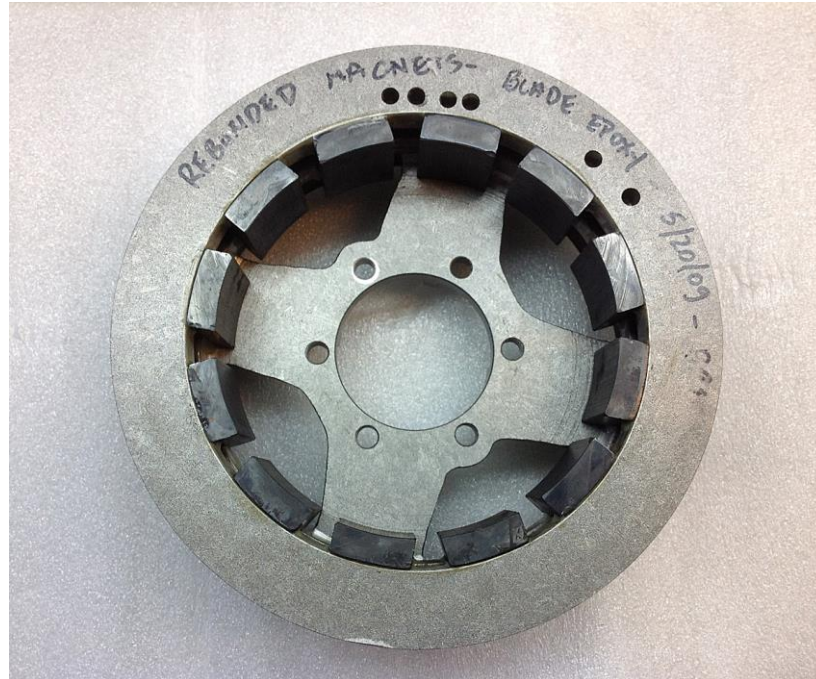
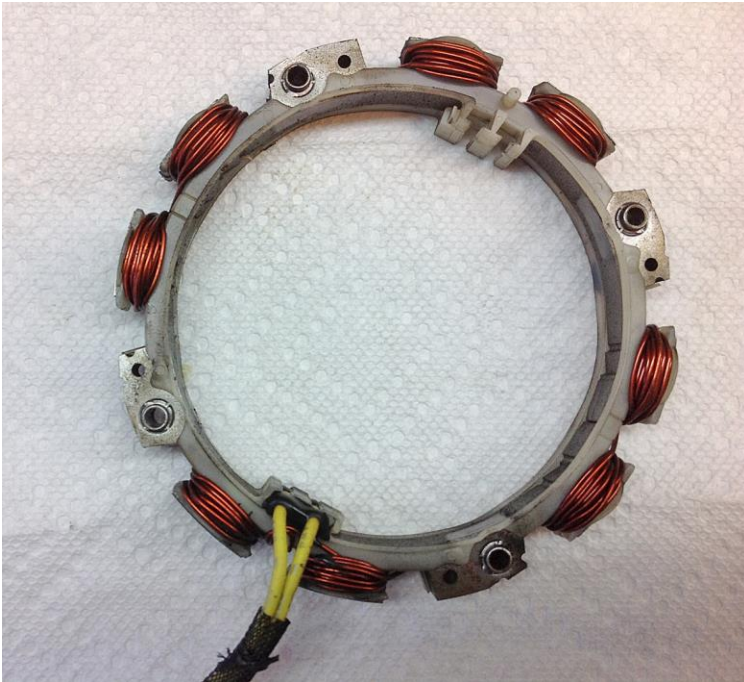

The existing factory charging system is designed around a riding lawnmower and is simplicity itself – there is a simple set of meager windings that are secured to the engine and a set of magnets that are epoxied inside the engine drive pulley. The factory “regulator” is really only a bridge rectifier that converts the pulsating AC output to DC. There is no voltage or current regulation and the current output is marginal.

AUTOMOTIVE ALTERNATOR CONVERSION FOR N750G

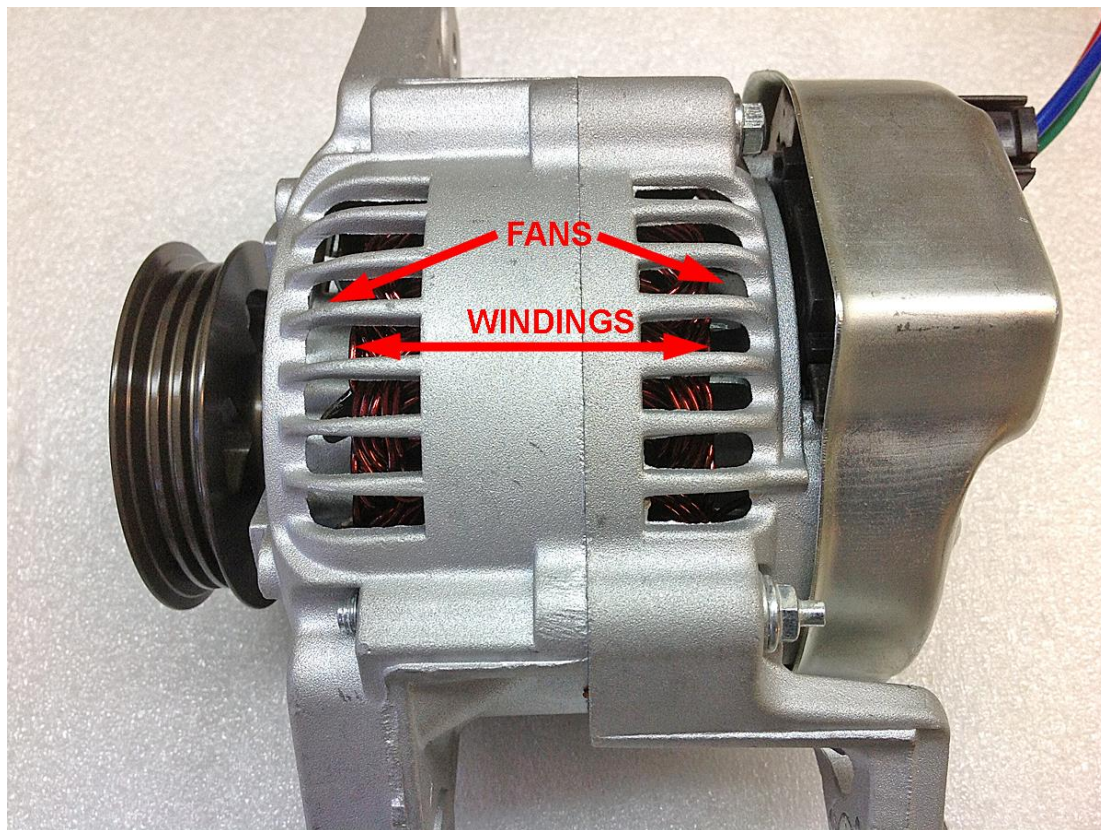

The automotive alternator I chose to use as my replacement has been proven reliable in countless fixed wing homebuilt aircraft installations and millions of automobiles.

It's much more sophisticated than the original, with a three-phase main winding and a field winding to control the output.

This particular unit has a cooling fan front and rear, massive windings by comparison, and a modern remote sensing regulator that will guarantee a full charge on my batteries every time. It's rated at 55 Amps.

AUTOMOTIVE ALTERNATOR CONVERSION FOR N750G

The heart of the new auto alternator installation is going to be the drive pulley. The next few pages show the new pulley as it will mount to the transmission pulley. The center hole will be a clearance fit around the transmission tail shaft and serve to align the drive pulley. The eight mounting bolts do not align the pulley, they simply attach it.

This new pulley is designed to match the profile of an after market alternator pulley which will make alignment of the alternator a fairly straightforward task. If the faces of the two pulleys are on the same plane then the belt will be perfectly aligned. A simple jig will aid in the installation.

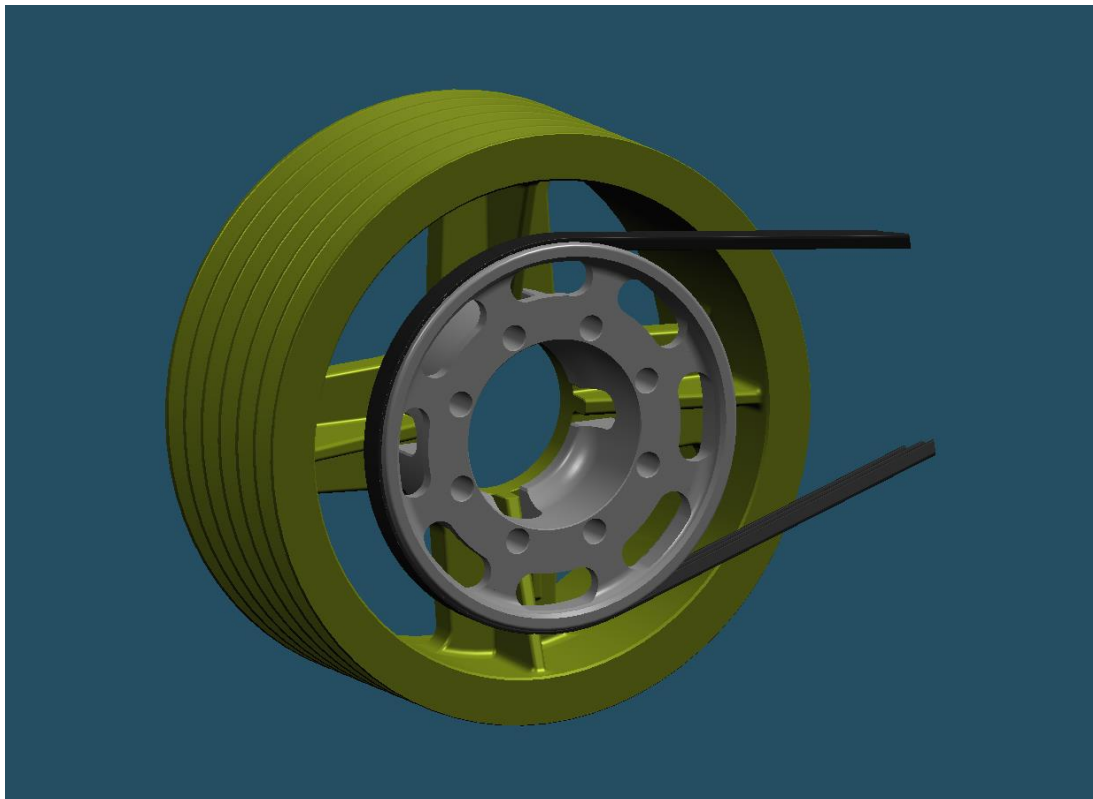

The drive pulley is CNC machined out of 6061 aluminum and hard coated for wear resistance. The alternator pulley is commercial off-the-shelf (COTS) from an automobile racing supplier. It is also milled from aluminum and hard coated

The new pulley is shown in gray and the existing transmission pulley is shown in green.

AUTOMOTIVE ALTERNATOR CONVERSION FOR N750G

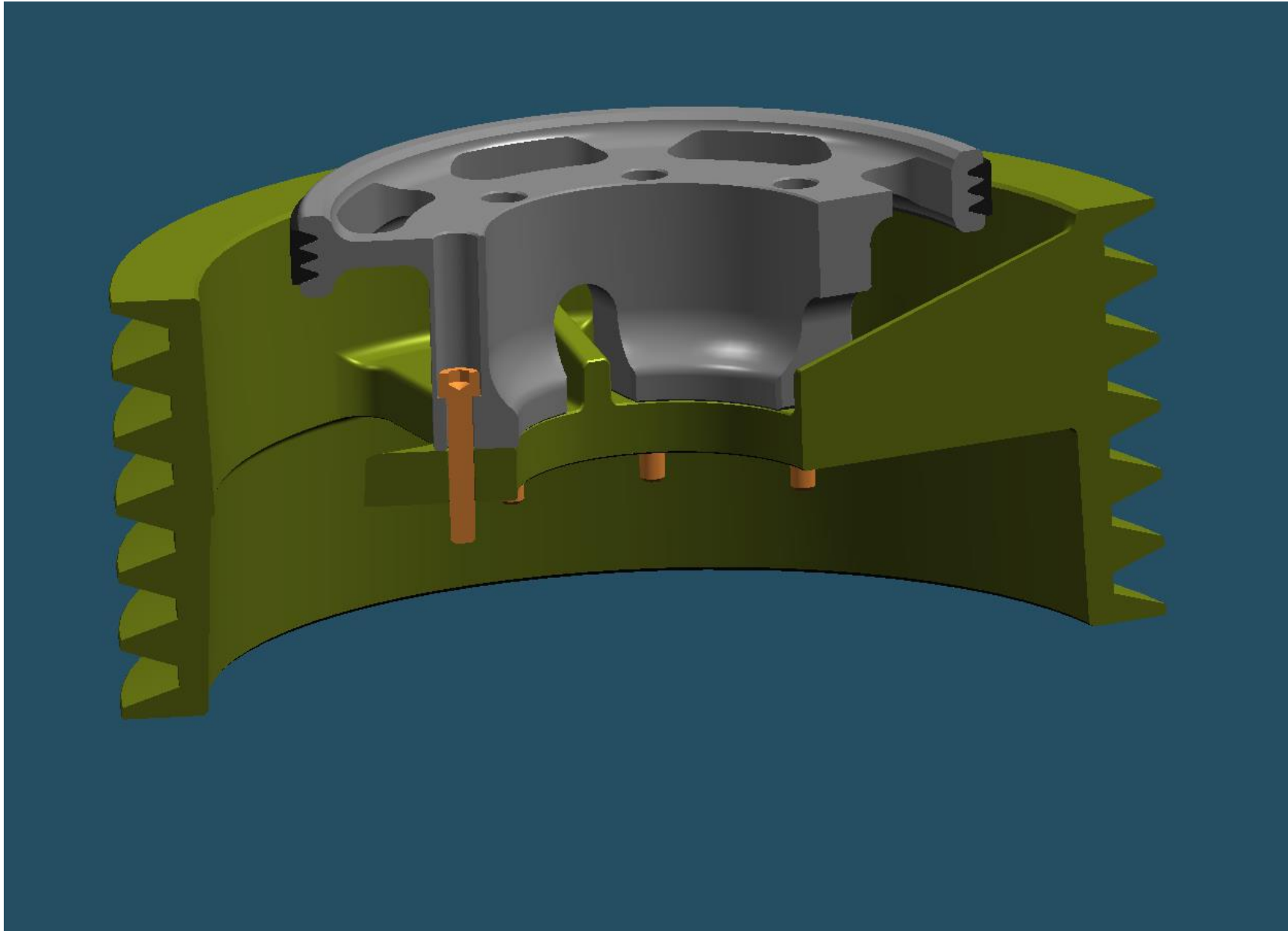

AUTOMOTIVE ALTERNATOR CONVERSION FOR N750G

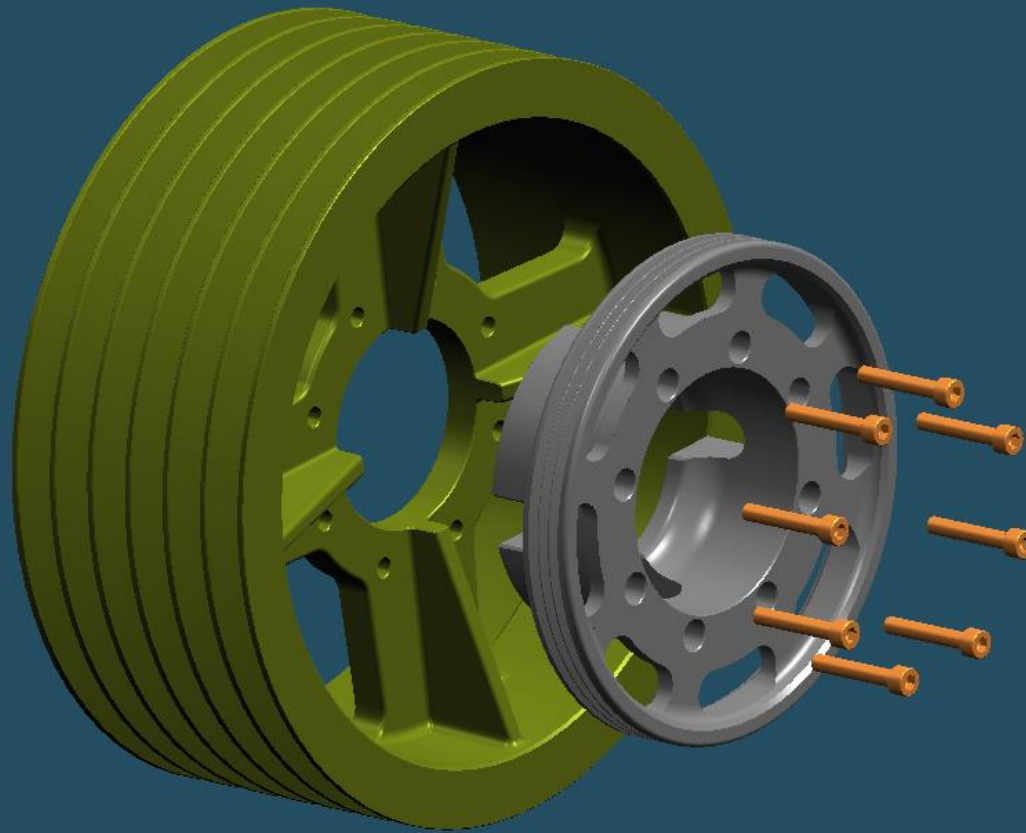

AUTOMOTIVE ALTERNATOR CONVERSION FOR N750G

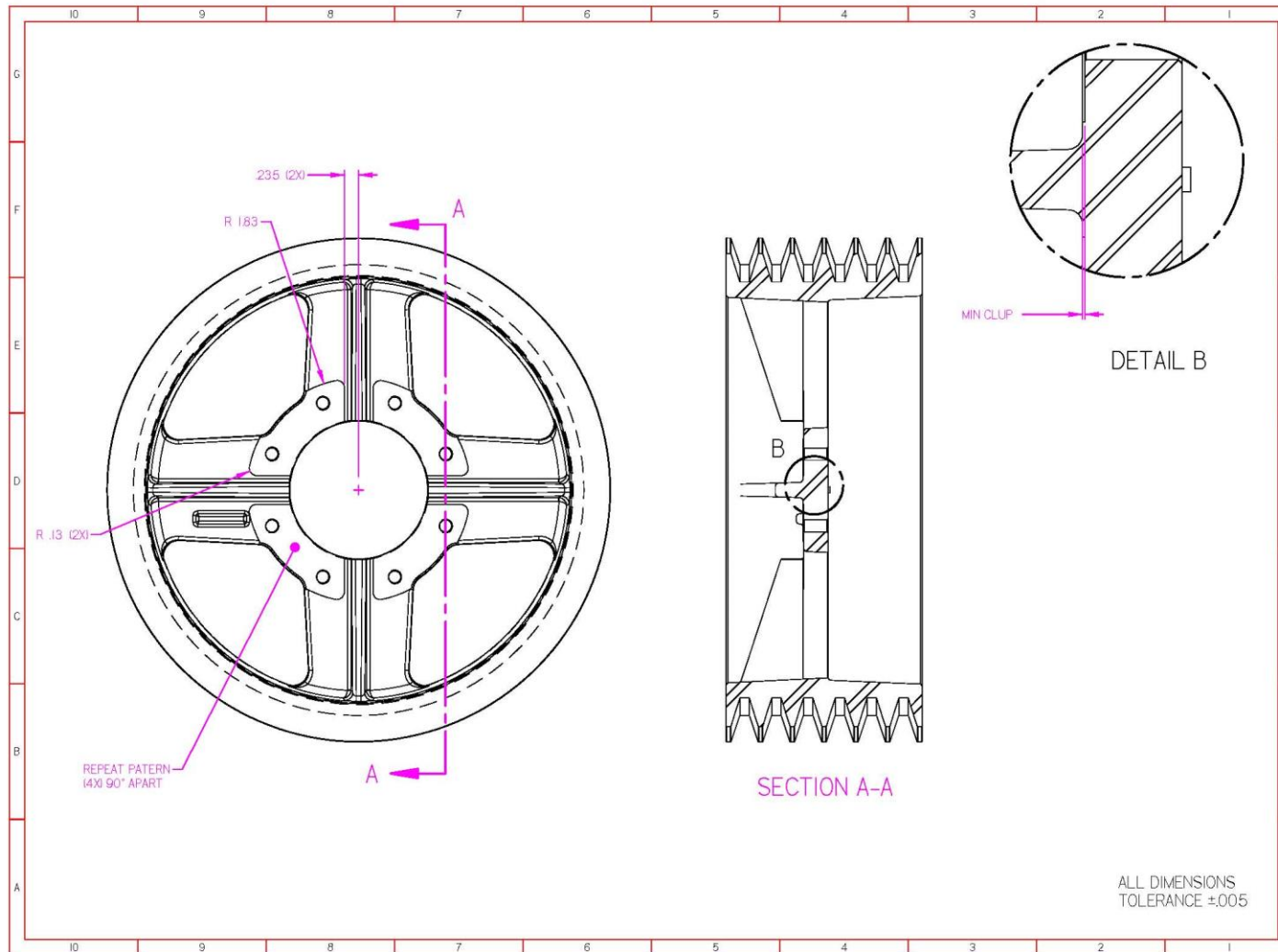

This drawing shows the cleanup area on the transmission pulley where the new drive pulley will mount. The fan ears must also be removed.

AUTOMOTIVE ALTERNATOR CONVERSION FOR N750G

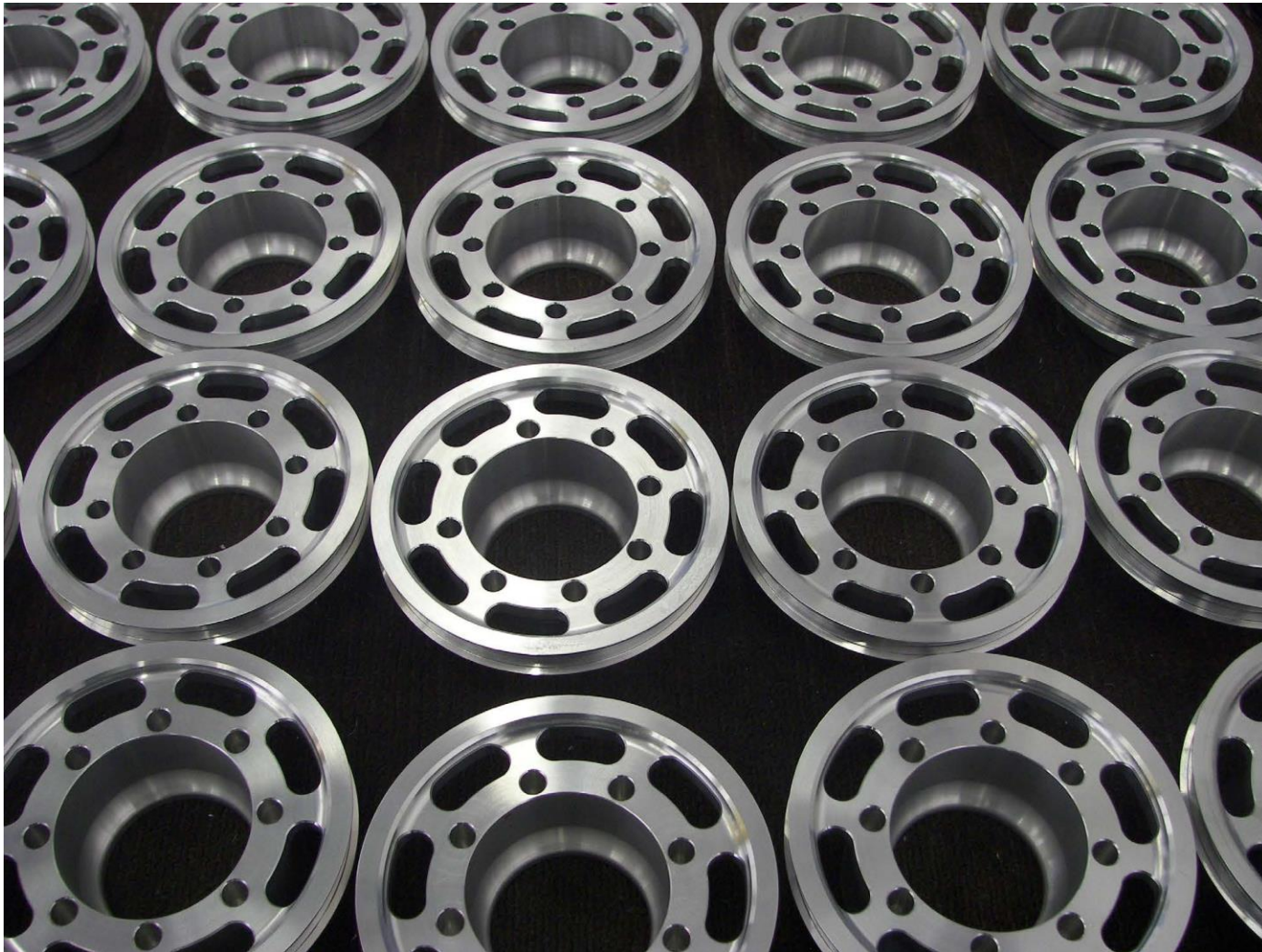

As of this week the pulleys have been machined and sent out for hard coating. This is a photograph of the aft side as it will be mounted to the transmission pulley.

AUTOMOTIVE ALTERNATOR CONVERSION FOR N750G



Here's a photograph of the pulleys viewed from the inside face that mates to the transmission pulley. Aren't they pretty? The eight slightly larger holes are for lightening and do not pass all the way through.

AUTOMOTIVE ALTERNATOR CONVERSION FOR N750G



Here's the after market alternator pulley. It's also milled from aluminum and hard coated. It's a very nice looking piece.

Once the drive pulleys are hard coated they should come close to matching the drive pulley color. It all depends on the exact plating parameters that are used – temperatures, currents, chemical purity, etc.

This is the back side of the transmission pulley. The alternator drive pulley mounts to the spokes in the middle and straddles the four webs. The tabs sticking up were from the day when the Helicycle was going to have a piston engine and needed fan blades for cooling. They are not used with the turbine engine and are in the way of the new alternator drive pulley. They will be

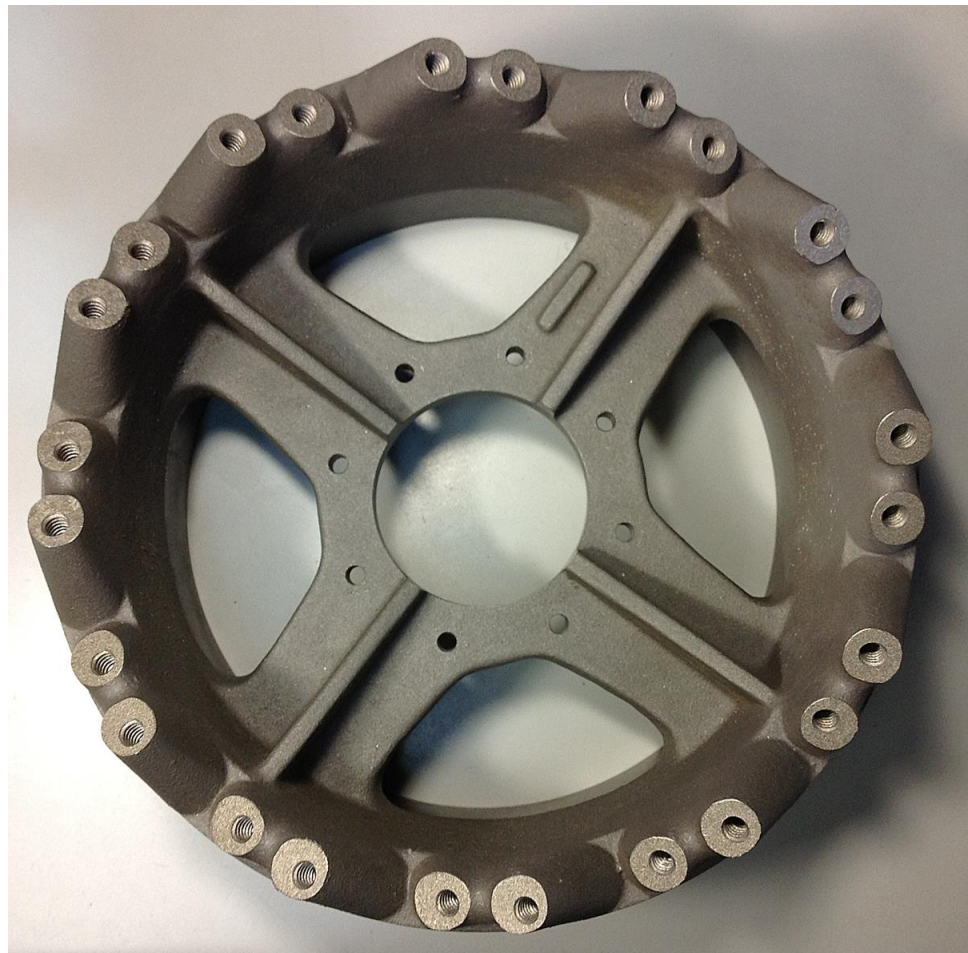

machined off; the mounting surface cleaned up per the drawing on page 6, and sent out for balancing along with the drive pulley. I'll also send the engine pulley since the magnets were re-epoxied to the pulley and I am not sure it was rebalanced. I've always had an engine vibration and this may be the cause.

AUTOMOTIVE ALTERNATOR CONVERSION FOR N750G

As I mentioned, the existing Helicycle charging system utilizes components from a riding lawnmower. It's actually a very clever approach and it seems to work for almost everyone. For some reason my charging system maxes out at about three amps. That's not enough to keep up with demand, let alone replenish the power required to start the engine. I could probably fiddle with it and get it up to a maximum of about 8 Amps, but it's just too marginal for my taste so I purchased a small automotive alternator that's rated at 55 Amps at 6000 RPM. The alternator is used on the Suzuki Samurai and is manufactured by Nippon Denso among others. It has a good track record in fixed wing homebuilt aircraft. The industry part number is 14684N. Here are a few pictures with the original pulley installed:



The alternator has an internal solid state regulator and a number of useful features:

- Remote sensing of battery voltage
- Charge lamp
- Internal cooling fans front and back

Remote sensing is important because it allows the regulator to take into account the voltage drop in the wiring between the alternator and the battery. Without this capability the battery will not get a full charge. I also like the charge light. It will call attention to a charging problem and then I'll know to look at the voltmeter on my lower panel.

NOTE: There may be even better alternators for this application. Other folks are looking into this now...

AUTOMOTIVE ALTERNATOR CONVERSION FOR N750G

There are two mounting options which are driven by the choice of pulleys. You can drive the alternator from the engine pulley and mount the alternator underneath the engine, or you can drive it from the transmission pulley and mount it on the right side of the engine.

There are a number of drawbacks to the engine pulley option as I see it:

- There are no robust mounting points – only socket-head cap screws that are located around the gear reduction case. This makes for a flimsy installation.
- The engine is loaded down by the alternator during starts and the engine is already a tremendous load on the starter motor.
- The alternator pulley will end up between the engine and the existing six belts making a belt change a chore.

As a result I opted to mount the alternator on the side of the engine. The first step is to figure out how to physically mount the unit without the need to weld to the frame and damage my powder coat. The answer is a sack of 0.750" two-piece diameter Shaft Collars from Grainger (P/N: 2ANV2) at \$11.84 each. I'll use those to clamp a mounting plate to the frame. I'll make it out of 0.25" 6061T6 aluminum. I picked up some scrap sheets of polycarbonate at Tap Plastic to use during the design so I can see what I'm doing.

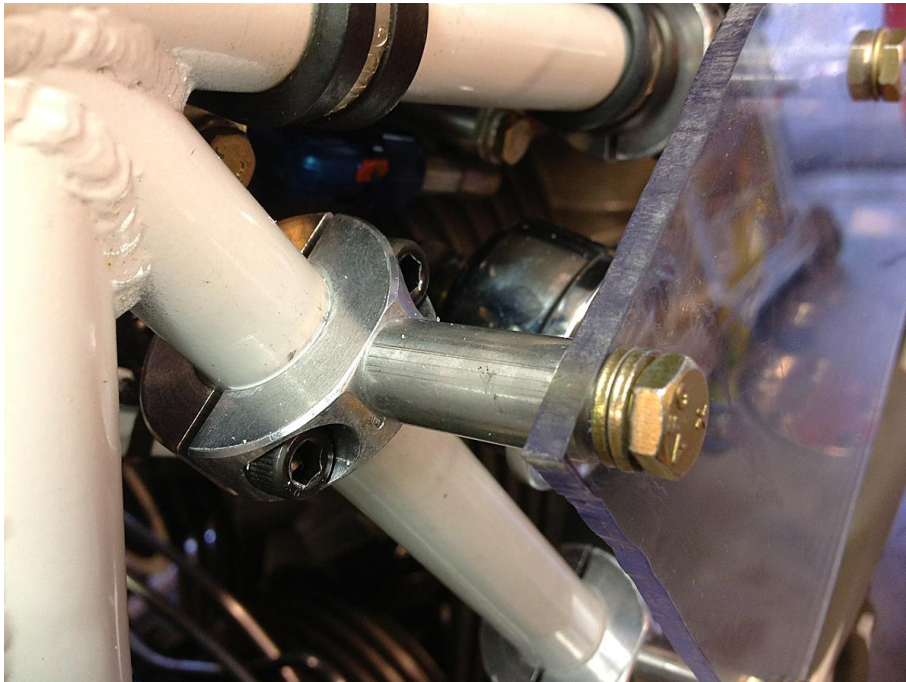

The mounting plate will be attached to the frame using four mounts – three of which form a triangle. The mounts consist of a modified two-piece shaft collar and a one-inch standoff. I machined a flat on each collar and tapped a 1/4-28 threaded hole to accept an AN aircraft bolt.

AUTOMOTIVE ALTERNATOR CONVERSION FOR N750G

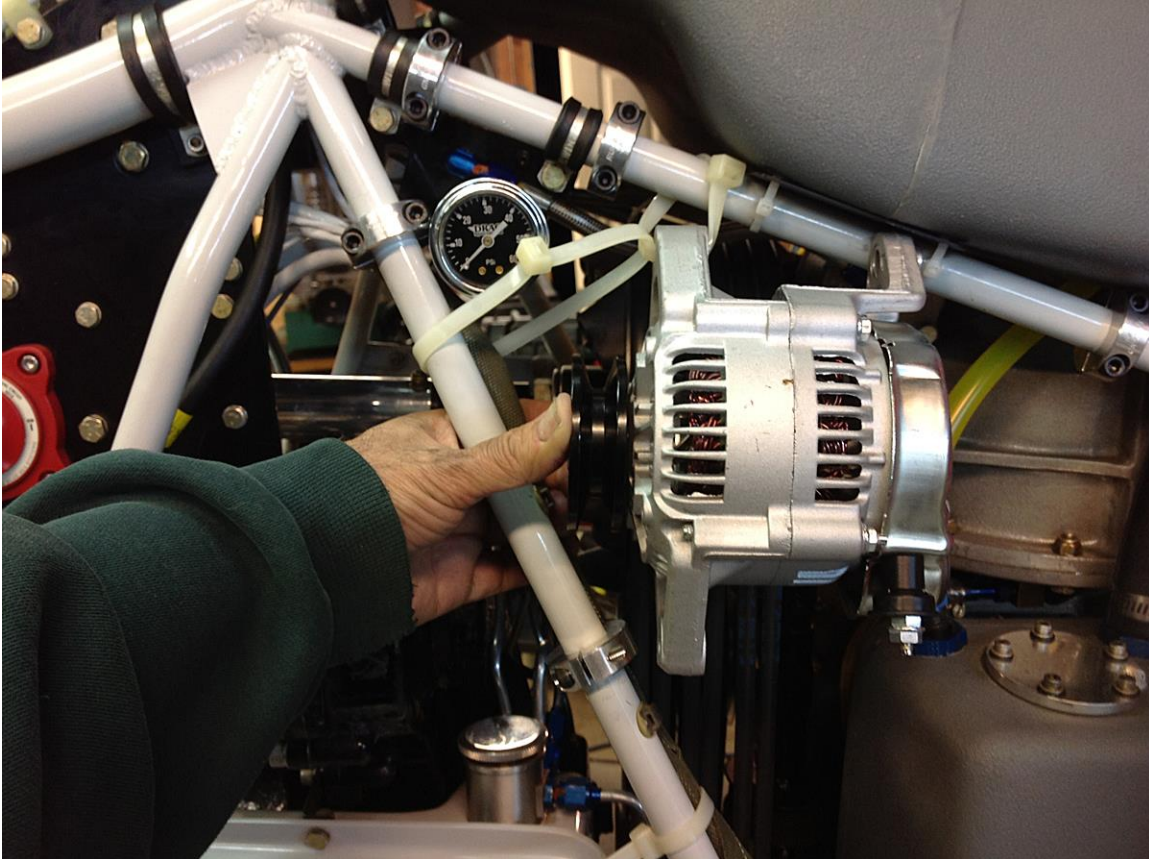

Here's the general location of the alternator which will sit behind the mounting plate.

There are two types of belt misalignment – parallel and angular. This plan takes them both into account... Considerable effort has gone into the design of the drive pulley to insure that the cross section of that pulley is exactly the same as the CV Products pulley, so if the plane of the two pulley faces are exactly parallel, the alternator will be aligned in X and Y axis and forward/reverse direction and the belt will be in perfect alignment.



Here's the CV Products pulley mounted on the alternator. You can see that getting the old pulley off was a struggle based on the nicks and dings on the nut. The goal of the alignment jig is to have the face of this pulley and the drive pulley both flush against the same surface of the jig's plate. Since there are not enough threads on the alternator shaft we'll need a spacer to take the place of the CV pulley. The spacer will go on after the original pulley is removed. This will be done rather simply using the flat plate and spacer shown on pages 13 through 15.

AUTOMOTIVE ALTERNATOR CONVERSION FOR N750G

The next few pages show what the alternator spacer looks like and how it will mount to the alternator and the drive pulley. The spacer is milled to the exact thickness of the alternator pulley.

We're shooting for an angular misalignment of less than one quarter degree and a parallel misalignment of less than twenty five thousandth of an inch. I think it will be possible to meet these requirements using this type of approach.

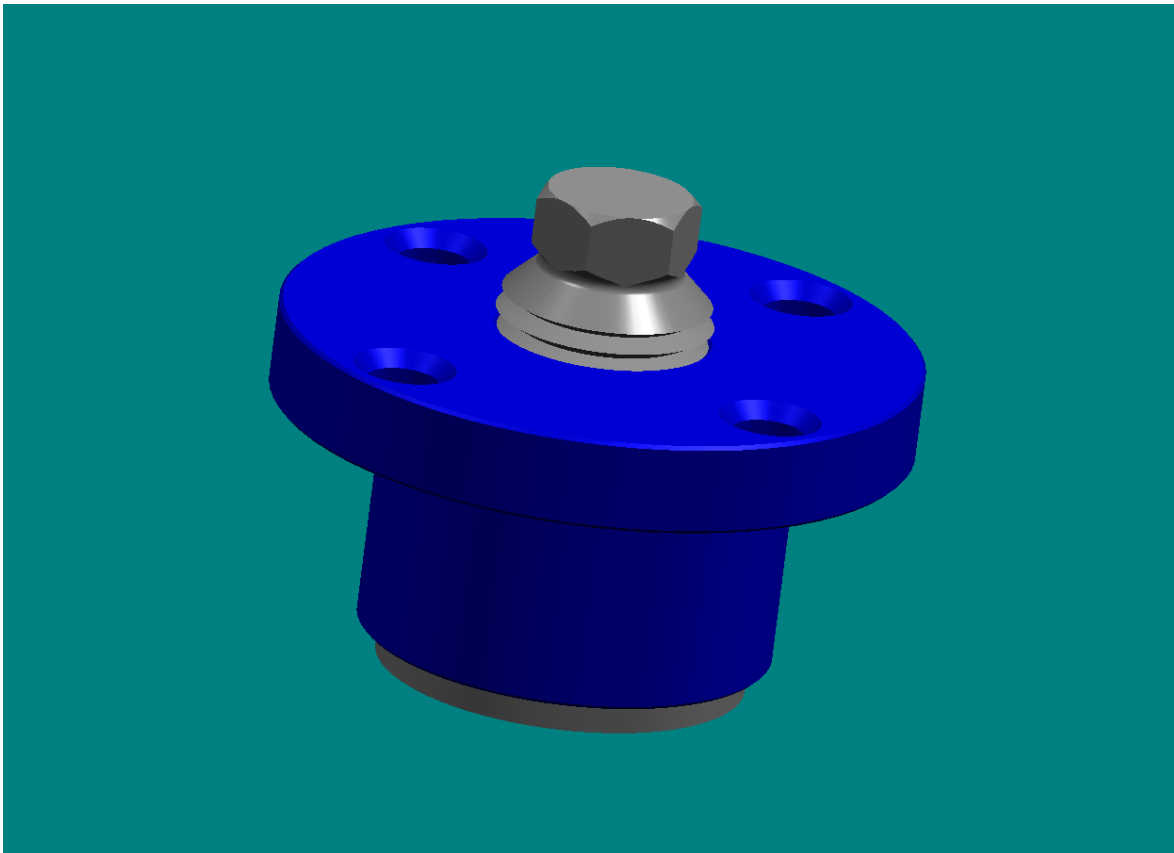

The alignment spacer, shown in blue, screws onto the existing alternator shaft shown in gray. The plate mounts to the face of this spacer.

AUTOMOTIVE ALTERNATOR CONVERSION FOR N750G

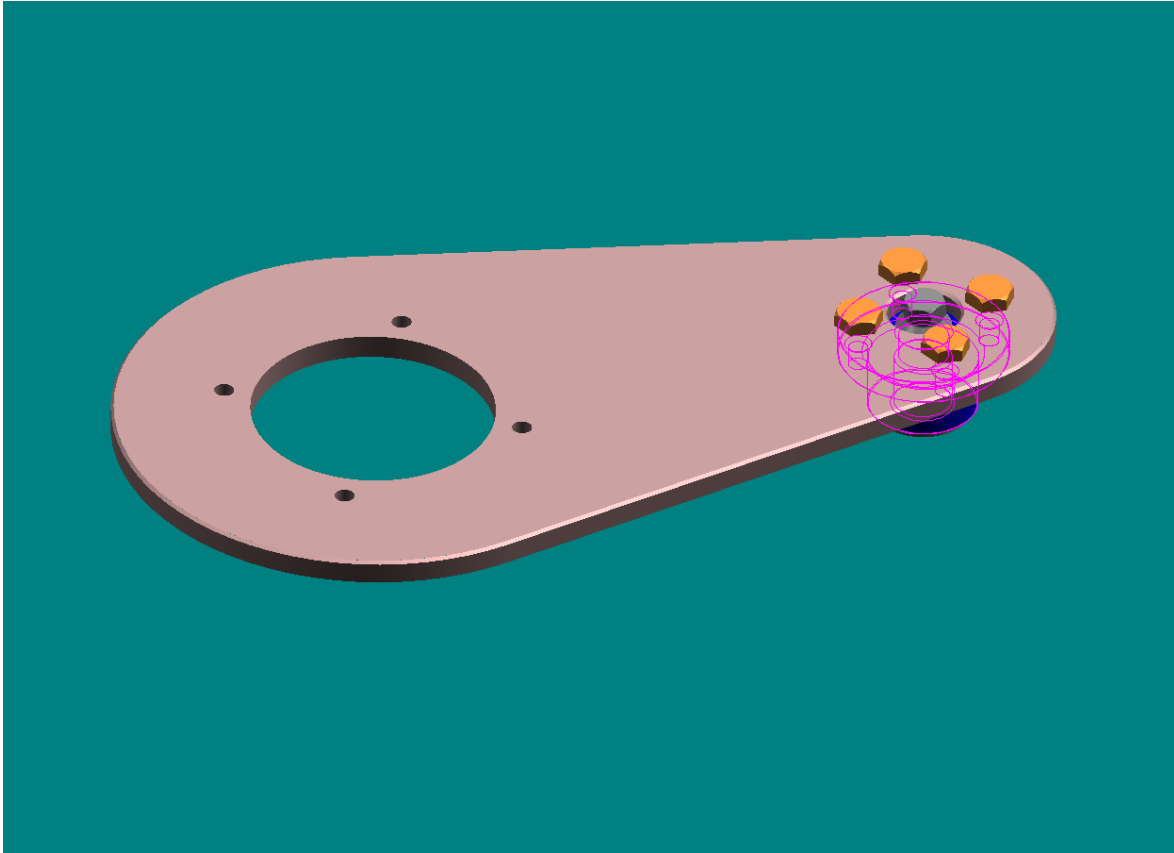

The spacer, with the alternator attached, mounts to this plate which mounts to the face of the drive pulley. This will perfectly align the two pulleys while the alternator mounting bracketry is being sorted out and installed. I'll certainly have much more on this once I have the spacer and the drive pulley in a week or two.

AUTOMOTIVE ALTERNATOR CONVERSION FOR N750G

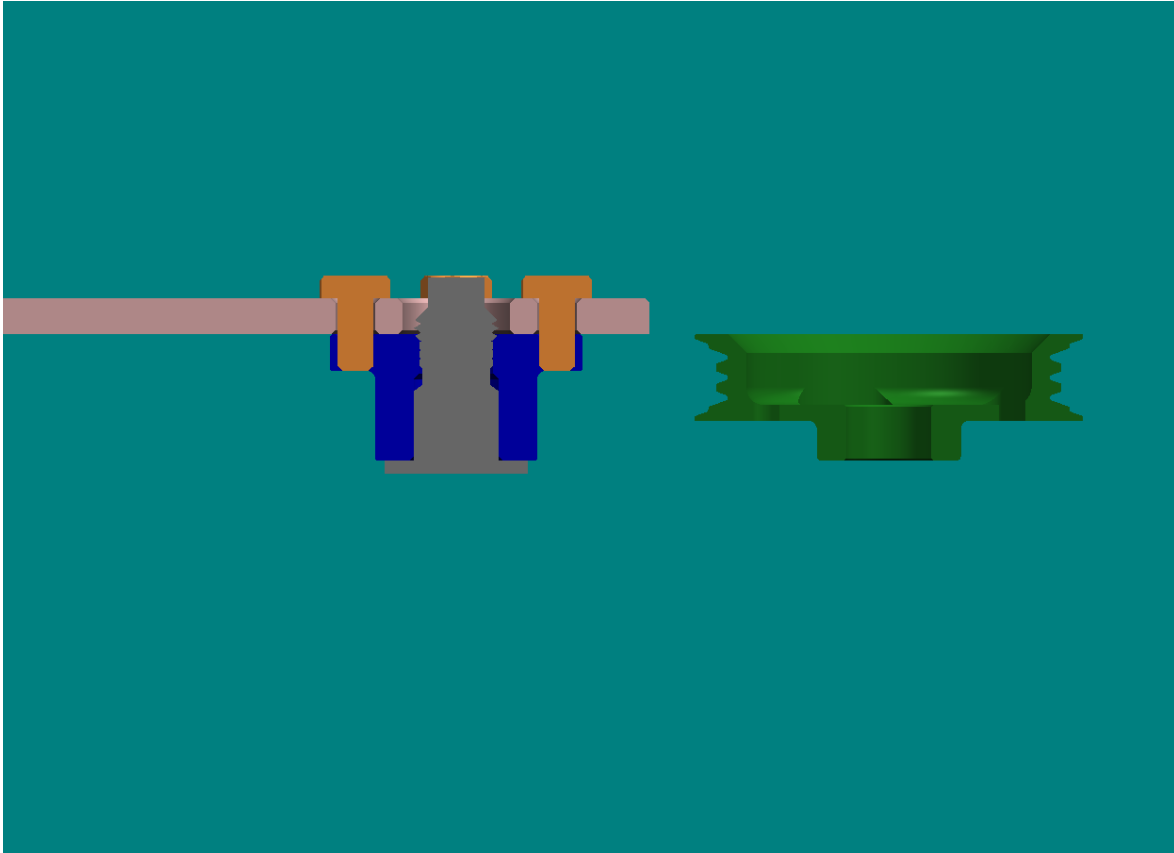

This is a side view showing that the plane of the two pulley faces will be exactly the same in all three axes.

I already have the alternator pulleys and new metric nuts and I should have the drive pulleys and spacers in a week or slightly more. I'll be sending them out as soon as they arrive.

Let the fun begin!

AUTOMOTIVE ALTERNATOR CONVERSION FOR N750G

Here's a partial bill of materials for the alternator portion of this project so far:

QTY, U/I	DESCRIPTION	P/N	VENDOR	COST
1 ea	Alternator, 12V, 55A, New	14684	Urqualitysolutions.com	\$129.95
1 ea	drive pulley and spacer		Juan Rivera	\$210
1 ea	3-Rib Belt	4030240	Local Auto Parts	\$12.95
2 ea	3-terminal connector	900-C1850	Jimco, Inc.	\$30.00
4 ea	Shaft Collar, 2-pc, .750 ID	2ANV2	Grainger	\$73.35
1 ea	Alternator Pulley	CVD60220	CV Products	\$46.23
1 ea	Removal of fan tabs and surfacing of mounting areas on upper pulley			\$
8 ea	Class 8, 3/16" socked head cap screws			\$
1 ea	6061T6 1/4" mounting plate			\$
1 set	Alternator Mounting bracketry			\$
3 ea	Circuit breakers or fuses and holders			\$
1 ea	Offset box wrench for CV Products pulley removal			\$

This list is academic at this point since I only made enough drive pulleys to satisfy the orders that I have plus a few extras that I will hang on to for a while. I have no plans to have more made.

For folks that are not satisfied with the factory charging system and didn't get in on this project, there are a number of other projects or on-going discussions that seem to have merit. You can rewind the existing windings, or you may be able to replace it with one that is used on a Harley Davidson. See the builder's discussion group for details...